

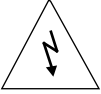





Warnings and Cautions

Warning 	Dangerous Voltage Warning: warns of situations in which a high voltage can cause injury and/or equipment damage. The text next to this symbol describes ways to avoid danger.
Warning 	General Warning: warns of situations that can cause physical injury and/or equipment damage by means other than electrical. The text next to this symbol describes ways to avoid the danger.

General Safety Instructions

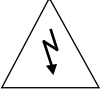
Warning 	Be sure to read, understand, and follow all safety instructions.
Warning 	Only qualified electricians should carry out all electrical installation and maintenance work on output filter.
Warning 	All wiring must be in accordance with the National Electrical Code (NEC) and/or any other codes that apply to the installation site.
Warning 	Disconnect all power before working on the equipment. Do not attempt any work on a powered output filter.
Warning 	The KLC, VFD, motor, and other connected equipment must be properly grounded.
Warning 	The VFD terminals and connected cables are at a dangerously high voltage when power is applied to the VFD, regardless of motor operation.

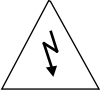
Field Wiring

KLCUL Field Wiring Connection Terminals
Compression type terminals are provided for all line wiring connections. The wire size capacity ranges and tightening torque for the power terminals are listed in the table.

KLCUL Model Numbers	Input and Output Motor Power	
	Wire Size	Torque (in. - lb.)
KLCUL2A to KLCUL12A	12 - 18	10
KLCUL16A to KLCUL55A	4 - 18	20
KLCUL80A	1 - 22	35
KLCUL110A to KLCUL130A	2/0 - 6	120
KLCUL160A to KLCUL200A	250 MCM - 6	275
KLCUL250A to KLCUL300A	600 MCM - 4 Two: 250 MCM - 1/0	500
KLCUL360A	Two: 350 MCM - 4	275
KLCUL420A to KLCUL600A	Two: 600 MCM - 2	500
KLCUL750A	Two: 800 MCM - 300 MCM	500

See www.transcoil.com for dimension tables

Please contact TCI Technical Support or your TCI distributor for application information regarding the use of KLC output filters on the output side of the VFD.



KLC/KLCUL Installation Guide

TCI, LLC
W132 N10611 Grant Drive
Germantown, WI 53022
Ph: 800-TCI-8282
www.transcoil.com

TCI, LLC
W132 N10611 Grant Drive
Germantown, WI 53022
Ph: 800-TCI-8282
www.transcoil.com

KLC/KLCUL Output Filter Installation Instruction

Installation Checklist

- Make sure that the installation location will not be exposed to direct sunlight, rain or dripping liquids, corrosive liquids or gases, explosive or combustible gases or dust, excessive airborne dirt and dust, or excessive vibration.
- Select a mounting area that will allow adequate cooling air and maintenance access.
- Make sure that all wiring conforms to the requirements of the National Electric Code (NEC) and/or other applicable electrical codes.
- Ground the KLC Output Filter to a dedicated system ground to ensure safety and filter performance. Use a properly sized grounding conductor.
- Wire the output power terminals of the VFD, T1(U), T2(V), & T3(W) to the input terminals of the KLC filters L1, L2, and L3.
- Wire the output power terminals, of the KLC, T1, T2, & T3 to the motor power connections.
- Make sure the VFD is set for operating modes and ranges that are compatible with the KLC Output Filter.
- Check the entire system thoroughly before energizing and operating any equipment.

When you receive the unit, you should immediately inspect the shipping container and report any damage to the shipping carrier who delivered the unit.

Verify the Application

Make sure the KLC output filter is correct for the application. The current ratings of the KLC should be sized to handle the FLA rating of the motor but not to exceed 110% of the drive output current rating. This output filter is best applied matched closely to the load. The KLC output filter is not selected by the drive input current rating.

Variable Frequency Drive Settings

Make sure that the variable frequency drive will be set for operation modes and ranges that are compatible with the KLC output filter:

- Maximum output frequency: 60 Hz

- PWM switching frequency best between 2kHz and 4kHz
- Mode of operation: Do not use with DC braking unless the drive application has been confirmed by TCI Technical Support.
- Do not use on overhauling loads without bus voltage control.

Mounting an open style unit

If you are mounting an open style unit in your own enclosure, you must provide an enclosure that is adequately sized and ventilated sufficiently to prevent overheating. The filter is designed with a maximum ambient temperature of 40°C (104°F). If the ambient temperature exceeds this value it is the responsibility of the customer to provide auxiliary cooling to reduce the ambient operating temperature around the KLC filter. TCI strongly recommends using auxiliary cooling devices such as cooling fans, heat exchangers, or possibly air conditioning units when required to maintain the proper operating temperature.

Position the KLC filter to be as close as possible (No greater than 20 ft.) from the drive output terminals. The KLC must be mounted so that the included line reactor is positioned vertically. Mounting it vertically is important for natural convection cooling.

Power Wiring

The conduit and wiring from the output of the variable frequency drive to the motor must be routed to the KLC and then to the motor. TCI recommends a separate dedicated conduit run for each drive/filter/motor run unless properly shielded and segregated wiring procedures are practiced. Parasitic and induced capacitance can greatly reduce the effectiveness of the filter performance. Under no circumstances should you wire both control and power wire in the same conduit unless the wire way is specifically designed for this practice. The unit temperature is sensitive to lead wire oversizing. Avoid lead wires more than five times oversized by copper cross sectional area and operating current, regardless of the material used. Use 75°C copper conductors only or the equivalent, unless the wire connector is marked for Al/Cu, then the use of aluminum wire is permitted. Use copper conductor only on units rated above 80 amps.

Wiring Cable Entry Locations

TCI has not provided knock-outs due to the wide variety of application requirements. TCI allows installing electricians the option of locating the cable openings at a point of their choosing.

Grounding

The KLC filter must be connected to the ground of the premises wiring system. This can be conducted by identifying a known premises ground near by the filter or running a special ground dedicated for this application. The ground connection must be made using a wire conductor. Metallic conduit is not a suitable grounding conductor. The integrity of all ground connections should be periodically checked.

Wiring Diagram

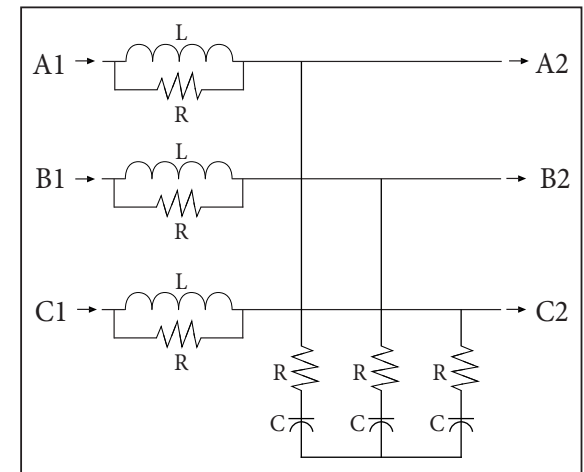

Product Specifications

- ▶ Current Rating: 2 - 750 Amps
- ▶ UL and cUL Listed
- ▶ Open, UL Type 1 and UL Type 3R Enclosures
- ▶ Efficiency > 98%
- ▶ Insulation Rating: 600V Class
- ▶ Insulation Class: Class H (180°C or better)
- ▶ Altitude (Maximum): 1000m
- ▶ Lead Length: 3000 ft. (specific applications, consult TCI Tech Support over 1000 ft.)
- ▶ Operating Temp: 40°C Ambient